

System 200 Data Sheet



The new BOFA system 200 is the smallest in the range of volume extraction systems. This compact unit is ideal for factory's with changing demands which result in production layout changes. The system 200 comes complete with its own installation kit for immediate extraction solutions.

Carcass

Main body, central support, lid and base are powder coated Zintac

Standard Equipment

- Weight: 7kg
- Filter condition light
- Noise level: below 53dba
- Integral silencer with air exhausted out the base of unit
- Standard Filter set (see below)
- 50mm Diameter inlet
- Thermal trip
- Installation kit (table bracket, Flip-top connector and 50mm flexible tubing)

Electrics

- 230v 1ph 50hz or 110v 1ph 60hz
- 2m Power Cord
- Fused IEC illuminated switch
- Full load current: 0.18 amps

Warranty

- 12 month warranty
- 12 month COSHH Certification

Standard Filter Set

Pre Filter
95% efficiency @ 0.8micron

Combined Filter
HEPA 99.997% @ 0.3 micron
Gas Filter media
Activated carbon impregnated with potassium permanganate

Maximum number of arms

50mm
EC: 1
US: 1

Blower / Pump

- Radial Ventilator
- 40,000 life hours
- Pressure 25m/bar
- 0.058k Output
- Airflow 90m³/hr
- IP54 Synchronous (brushless) motor

Options

VOC Monitoring

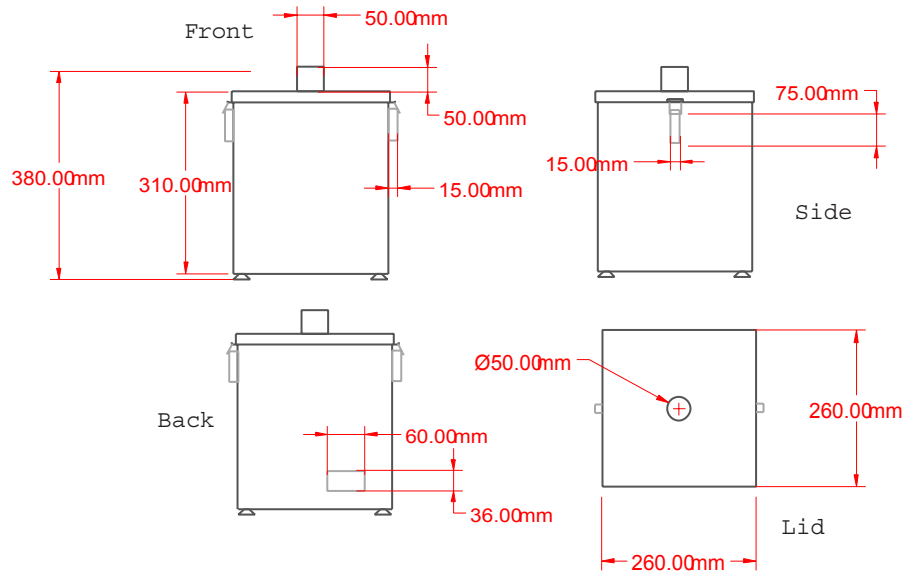

The system 200 comes complete with the installation kit shown opposite. This includes 50mm flexible tubing, table brackets, mounting plates, flush system seal Flip top connector and adaptor with balancing valve.

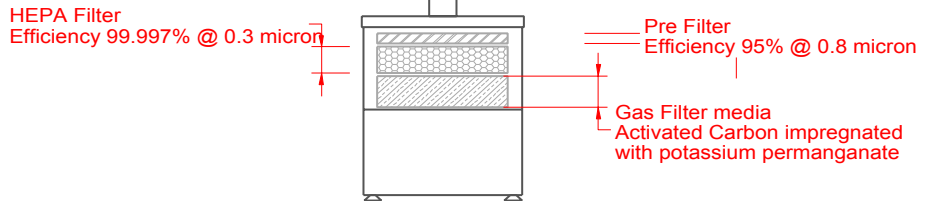

The chart opposite shows the maximum number of soldering arms that the System 200 is capable of extracting from.

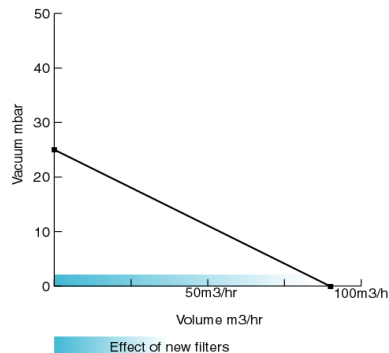
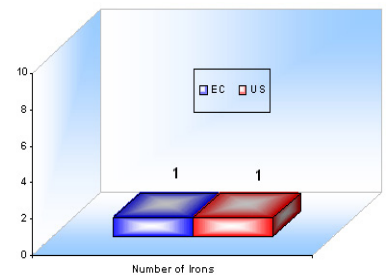

The chart opposite shows the performance of the pump within the System 200. The performance curve also highlights the effect of new filters on the new System 200's vacuum capabilities